

Hygiene & Transfer

Transactive Xtra

Innovation and multi-functionality at the service of transfer

Ceiling hoist

REF. 1668.11 - 1668.12 - 1668.13 - 1668.14 - 1668.15 - 1668.69



Ergonomic, economical and reliable, the Transactive lift is the innovative solution for patient transfer. Its modularity and ease of use meet all implementation issues, and provide high-performance and functional equipment.

REVAL
SUSTAINABLE WELL-BEING

Hygiene & Transfer

Transactive Xtra



- Lifting capacity ranging from 130 to 280kg.
- Submersible pneumatic remote control.
- 2 point strap holder with anti-strap detachment device.
- Quick release device for removing the strap holder.
- Compact device for better lifting range.
- Large selection of straps.
- Manual emergency ascent and descent and electric.
- Anti-twist system of the lifting strap.

Ceiling hoist

REF. 1668.11 - 1668.12 - 1668.13 - 1668.14 - 1668.15 - 1668.69

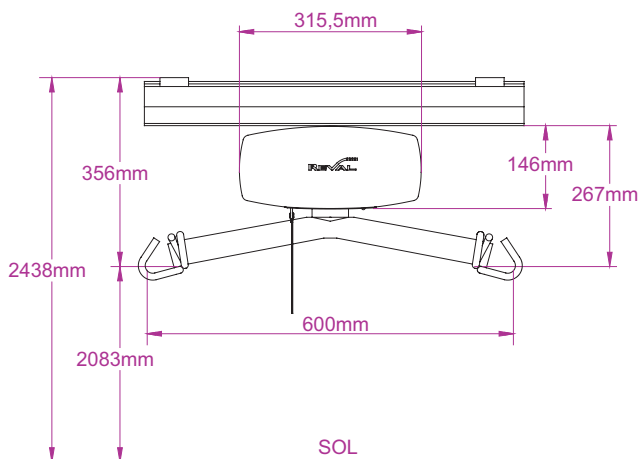

VERSIONS:

- 1668.11 Transactive Xtra 4 functions 160Kg lift
- 1668.12 Transactive Xtra 2 functions 160Kg lift
- 1668.13 Transactive Xtra 4 functions 200Kg lift
- 1668.14 Transactive Xtra 2 functions 200Kg lift
- 1668.15 Transactive Xtra 4 functions 280Kg lift
- 1668.69 4 functions TXE200D lift for rotating table and motorized XY system.
(2 additional buttons on the control and connection pads on the elevator allowing you to control and power a rotating table or a motorized XY system)

OPTIONS:

- 1668.16 2-4 button infrared conversion kit
- 1668.17 6 button infrared conversion kit

DESCRIPTION:

- Digital screen for battery levels, settings and maintenance.
- Motor movement on high precision ball bearings.
- Compact device for better lifting range.
- Automatic standby in case of prolonged non-use.
- Audible and visual battery discharge alarm.
- Overload safety.
- Emergency stop and electric emergency descent.
- Smooth engine start and stop.
- Charging station integrated into the rail.
- Quick removal of the motor by removing the end of rail stop.

TECHNICAL CHARACTERISTICS:

- Maximum lifting capacity 160, 200, 280, 300 kg
- Weight of the device:
 - 9.7 kg 2-function version
 - 10.4 kg 4/5 function version
- Lifting speed under load: 15cm/s
- 4 travel speeds for the 5-function version with automatic return to load.
- 2 Batteries 2x12V.
- Autonomy approximately 65 ascents/descents at 85 kg.
- Maximum battery charging time: 8 hours.
- IP67 230V/30V 50/60Mhz charger.
- Infrared control option available.

OPTIONS:

- Infrared control option available.

COMPLIANCE:

- 93/42/EEC Class I (Medical Devices Directive) • 73/23/CEE (Directive Basse Tension)
- 73/23/EEC (Low Voltage Directive)
- 89/336/EEC (Electromagnetic Compatibility Directive)
- EN 10535 (patient lifts)